



Applications

Thimbles are used to protect steel wire rope, fibre rope or synthetic rope. They are available in various models and sizes. All indicated types of thimbles can be used in combination with the above mentioned types of ropes.

Range

Van Beest offers a wide range of thimbles, from nationally standardized models to all types of commercially available thimbles.

Design

Thimbles can be cold-rolled, hot-rolled or die-cast, depending on the specific use of the thimbles.

Finish

The finish is either painted, electro-galvanized or hot dipped galvanized, unless otherwise specified.

Certification

Upon request, all thimbles can be supplied with a works certificate.

Instructions for use

It is required that the thimbles are regularly inspected and the inspection should take place in accordance with the standards given in the country of use.

This is required because the products in use may be affected by wear, misuse, overloading with a consequence of deformation and or alteration of the steel structure.

The dimensions of the thimbles must be so that the (wire) rope fits properly into the groove of the thimble. The nominal size of the thimble is the diameter of the (wire) rope with which it is intended to be used. For (wire) ropes of intermediate sizes, the next larger size of thimble must be used.

Before use, check if the thimble is free from impurities, sharp edges, cracks or other irregularities which may damage the wire rope and therefore affect the strength or reliability of the wire rope.

Thimbles

standard commercial

- **Material** : mild steel
- **Finish** : electro-galvanized
- **Certification** : a works certificate can be supplied upon request



E-6110

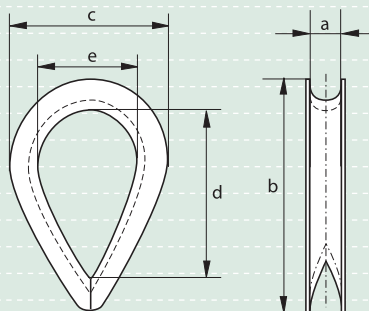

diameter rope	width groove	length	width	length inside	width inside	weight per 100 pcs
mm	a mm	b mm	c mm	d mm	e mm	kg
4	4	25	19	16	11	0.4
5	5	31	22	22	16	0.8
6	6	37	29	26	19	1.4
7	7	44	32	32	22	2
8	8	51	38	34	24	2.8
9	9	57	42	38	29	3
10	10	64	44	42	32	4.8
11	11	70	51	48	35	7.5
12	12	76	57	51	38	8
14	14	82	60	57	40	10
16	16	89	64	60	42	15
18	18	102	69	67	45	22
20	20	115	79	76	51	25
22	22	127	89	83	54	32
24	24	140	102	88	64	46
26	26	152	105	102	68	66
28	28	165	115	110	73	77
30	30	178	121	115	79	80
32	32	203	133	140	93	130

Thimbles

heavy duty stub-end

- **Material** : mild steel
- **Finish** : electro-galvanized
- **Certification** : a works certificate can be supplied upon request



E-6120

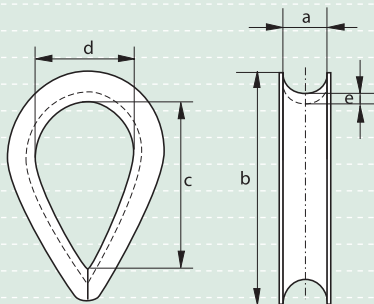

diameter rope	width groove	length	length inside	width inside	thickness back	weight per 100 pcs
mm	a mm	b mm	c mm	d mm	e mm	kg
8	8	51	35	22	4	6
10	10	64	47	30	4	7
12	12	76	57	35	5	14
14	14	89	65	45	6	22
16	16	102	76	50	6	24
18	18	114	86	53	8	43
20	20	127	94	60	9	65
22	22	140	107	65	10	93
24	24	152	114	70	10	102
28	28	178	130	80	10.5	135
32	32	203	157	100	10.5	162
36	36	229	177	115	12	363
40	40	254	198	120	12	376
44	44	279	214	130	15	608
50	50	305	215	140	20	960
56	56	356	245	160	20	1400
64	64	407	275	180	20	1700



E-6131
G-6131

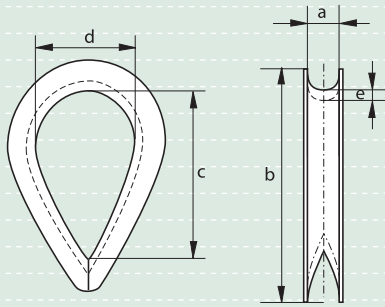

Thimbles generally to DIN 6899 (B)

- **Material** : mild steel
- **Standard** : generally to DIN 6899 (B)
- **Finish** : thimbles for rope diameters up to and including 6 mm are electro-galvanized, other diameters are hot dipped galvanized
- **Certification** : a works certificate can be supplied upon request

diameter rope	width groove	length	length inside	width inside	thickness back	weight per 100 pcs
mm	a mm	b mm	c mm	d mm	e mm	kg
2.5	3	22	19	12	1.6	0.5
3.5	4	26	21	13	1.6	0.8
4	5	32	23	14	1.9	1
5	6	38	25	16	2.4	1.6
6	7	44	28	18	2.4	1.9
7	8	51	32	20	2.8	3
9	10	57	38	24	3.1	4.7
11	12	64	45	28	3.3	6.8
13	13	70	48	30	3.3	8
13	14	76	51	32	3.7	10
15	16	83	58	36	3.8	14.5
16	17	89	61	38	4.7	18
17	18	95	64	40	4.7	20
18	20	102	72	45	5.7	29
20	22	114	80	50	5.7	32
22	24	127	90	56	6.5	47
24	26	140	99	62	6.8	59
26	28	152	112	70	8	80
28	30	165	120	75	8	110
30	32	178	128	80	8	123
32	34	203	152	95	8.5	156
34	36	216	160	100	8.5	176
36	38	229	176	110	8.5	192
38	40	241	184	115	10.5	292
40	42	254	192	120	10.5	320
42	45	305	240	150	10.5	364



G-6132

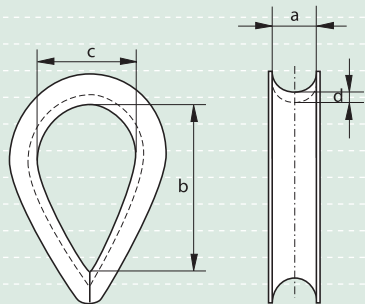

Thimbles

generally to DIN 6899 (C)

- **Material** : mild steel
- **Standard** : generally to DIN 6899 (C)
- **Finish** : hot dipped galvanized
- **Certification** : a works certificate can be supplied upon request

diameter rope	width groove	length inside	width inside	thickness back	weight per 100 pcs
mm	a mm	b mm	c mm	d mm	kg
11	12	59	27.5	6.5	24
12	13	64	30	7	25
14	15	75	35	8	35
16	18	86	40	9.5	65
18	20	96	45	11	102
20	22	107	50	12	135
22	24	118	55	13	179
24	26	128	60	14.5	227
26	28	139	65	15.5	264
28	31	150	70	17	400
32	35	171	80	19	520
36	40	192	90	21.5	575
40	44	215	100	24	1010
44	48	235	110	26.5	1180
48	53	257	120	29	1940



G-6133

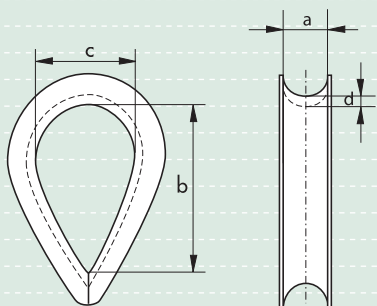

Thimbles

generally to DIN 83311

- **Material** : mild steel
- **Standard** : generally to DIN 83311
- **Finish** : hot dipped galvanized
- **Certification** : a works certificate can be supplied upon request

nominal size	width groove	length inside	width inside	thickness back	weight per 100 pcs
	a mm	b mm	c mm	d mm	kg
0.4	8	36	20	3	4.5
0.6	11	50	28	4	9.5
1	13	60	32	5	18
1.6	15	68	38	6	24
2	17	76	42	7	38
2.5	19	85	48	8	50
3	21	95	53	9	70
4	24	110	60	10	110
5	28	125	70	10.5	141
6	30	135	75	12	254
8	34	150	85	13	282
10	38	170	95	15	418
12	42	190	105	16	513
16	46	205	115	16	550
20	50	225	125	18	930
25	56	250	140	20	1303
31	62	280	155	21	1363
40	68	306	170	23	1930



E-6135
G-6135

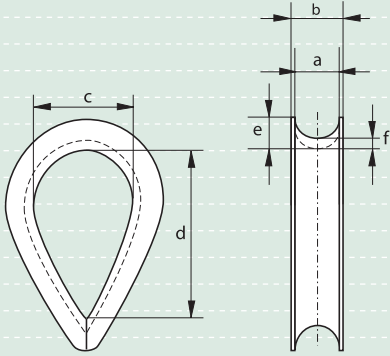

Thimbles generally to DIN 3090

- **Material** : mild steel
- **Standard** : generally to DIN 3090
- **Finish** : for diameter 4 and 6 mm electro-galvanized
other diameters hot dipped galvanized
- **Certification** : a works certificate can be supplied upon request

diameter wire rope	width groove	width overall	width inside	length inside	thickness	thickness back	weight per 100 pcs
mm	a mm	b mm	c mm	d mm	e mm	f mm	kg
4	5	9	10	20	5.1	2.1	1.4
6	7	12	15	30	7.1	2.6	3
8	9	13	20	40	11	4	7.1
10	11	16	25	50	14	5	17
12	13	19	30	60	16	6	24
14	16	22	35	70	17	7	36
16	18	25	40	80	19	8	50
18	20	27	45	90	21	9	62
20	22	32	50	100	23	10	90
22	24	33	55	110	24	10	100
24	26	37	60	120	27	11	130
26	29	46	65	130	30	12	220
28	31	50	70	140	33	12	240
32	35	55	80	160	38	14	270
36	40	60	90	180	42	16	430
40	44	65	100	200	46	18	570
44	48	70	110	220	53	20	850
48	53	75	120	240	58	22	1120
52	57	80	130	260	64	25	1530
56	62	85	140	280	67	25	2148
60	66	90	150	300	70	25	2300
64	70	95	160	320	78	30	3500
68	75	100	170	340	81	30	3700
72	79	105	180	360	84	30	4100
76	84	115	190	380	87	30	4600
80	88	120	200	400	90	30	5400



S-6134

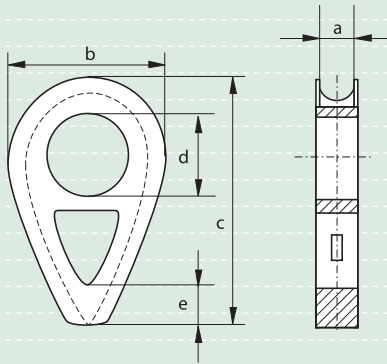

Thimbles

generally to DIN 3091

- **Material** : cast mild steel, (GTW 40)
- **Standard** : generally to DIN 3091
- **Finish** : self coloured
- **Certification** : a works certificate can be supplied upon request

diameter rope	width groove	width	length	diameter	length	weight per 100 pcs
mm	a mm	b mm	c mm	d mm	e mm	kg
8	9	40	66	14	-	18
10	11	50	82	18	-	32
12	13	60	98	21	-	52
14	16	70	114	25	-	80
16	18	80	130	28	16	90
18	20	90	145	31	18	121
20	22	100	161	35	20	161
22	24	110	177	38	22	211
24	26	120	193	41	24	271
26	29	130	209	44	26	355
28	31	140	224	47	28	420
32	35	160	256	53	32	630
36	40	180	288	59	36	884
40	44	200	320	65	40	1100
44	48	220	352	70	44	1500
48	53	240	384	76	48	2000
52	57	260	416	81	52	2500
56	62	280	448	86	56	3200
64	70	320	512	95	64	4600
72	79	360	576	104	72	6600
80	88	400	640	112	80	9000

1

2

3

4

5

6

7

8

9

10

11

12

13

14

15

16



G-6170

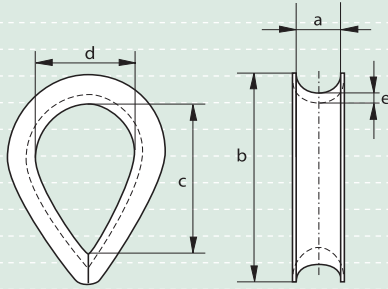

Thimbles generally to EN13411-1

- **Material** : mild steel
- **Standard** : generally to EN13411-1 formerly BS 464
- **Finish** : hot dipped galvanized
- **Certification** : a works certificate can be supplied upon request

diameter rope	width groove	length	length inside	width inside	thickness back	weight per 100 pcs
inches	a mm	b mm	c mm	d mm	e mm	kg
1/4	6	48	30	20	3.5	5.4
5/16	8	54	33	22	4	5.7
3/8	10	64	38	25	4.8	7.6
7/16	13	73	41	29	4.8	14.2
1/2	14	80	44	32	5.6	18
9/16	15	80	44	32	5.6	18.9
5/8	17	98	59	41	7.9	34
11/16	19	108	67	44	7.9	39.7
3/4	20	124	73	51	9.5	62.4
13/16	21	124	73	51	9.5	62.4
7/8	23	133	83	57	9.5	75.6
15/16	25	146	92	64	10.3	106
1	27	162	108	70	10.3	125
1 1/8	29	178	111	76	12.7	151
1 1/4	33	197	133	95	12.7	204
1 3/8	38	229	152	105	15.9	318
1 1/2	41	254	165	114	17.5	488
1 5/8	46	254	165	114	17.5	499
1 3/4	51	286	178	127	25.4	556
1 7/8	60	318	191	133	28.6	-
2	64	330	203	140	28.6	-
2 1/8	64	330	203	140	28.6	-
2 1/4	67	356	216	146	30.2	-
2 1/2	70	413	241	159	31.8	-
2 3/4	86	502	273	203	41.3	-

Thimbles generally to US Fed. Spec. FF-T-276b type III

- **Material** : mild steel
- **Standard** : generally to US Federal Specification FF-T-276b type III
- **Finish** : hot dipped galvanized
- **Certification** : a works certificate can be supplied upon request



G-6142

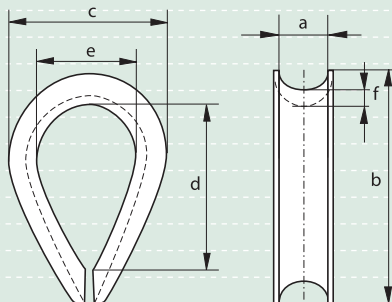

diameter rope	length	width	length inside	width inside	thickness back	weight per 100 pcs
a inches	b inches	c inches	d inches	e inches	f inches	kg
1/4	2 3/16	1 1/2	1 5/8	7/8	1/16	3.4
5/16	2 1/2	1 13/16	1 7/8	1 1/16	5/64	6.3
3/8	2 7/8	2 1/8	2 1/8	1 1/8	7/64	11.3
7/16	3 1/4	2 3/8	2 3/8	1 1/4	1/8	16.2
1/2	3 5/8	2 3/4	2 3/4	1 1/2	9/64	23
9/16	3 5/8	2 11/16	2 3/4	1 1/2	9/64	23
5/8	4 1/4	3 1/8	3 1/4	1 3/4	5/32	33.8
3/4	5	3 13/16	3 3/4	2	7/32	66.2
7/8	5 1/2	4 1/4	4 1/4	2 1/4	7/32	83.3
1	6 1/8	4 15/16	4 1/2	2 1/2	1/4	135
1 1/8 - 1 1/4	7	5 7/8	5 1/8	2 7/8	1/4	185
1 1/4 - 1 3/8	8 1/16	6 13/16	6 1/4	3 1/2	1/2	375
1 3/8 - 1 1/2	9	7 1/8	6 1/2	3 1/2	1/2	540
1 5/8	11 1/4	8 1/8	8	4	1/2	731
1 3/4	12 3/16	8 1/2	9	4 1/2	1/2	810
1 7/8 - 2	15 1/8	10 3/8	12	6	1/2	1170
2 1/4	17 1/8	11 7/8	14	7	1/2	1935
2 1/2	18 1/4	12 1/4	14 7/8	7	3/4	-
3	20 1/4	14	16 1/2	7 7/8	3/4	-

Thimbles

towing type

- **Material** : mild steel
- **Finish** : hot dipped galvanized
- **Certification** : a works certificate can be supplied upon request
- **Options** : thicker material
reinforced back
welded fillet plate
various links
keeper bands



G-6160

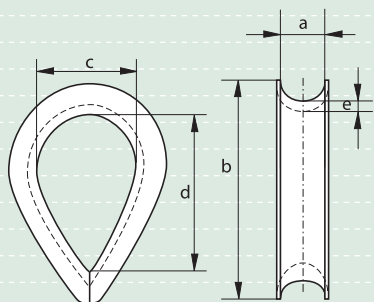

circumference rope	width groove	length	width inside	length inside	thickness back	weight per piece
inches	a mm	b mm	c mm	d mm	e mm	kg
5	44	200	90	140	6	2
6	54	230	100	160	8	3
7	62	270	120	190	8	4
8	70	290	130	200	8	5
9	80	360	150	235	10	9.5
10	90	400	160	245	10	11.5
12	100	430	170	260	10	13.5
13	120	480	170	280	13	22
14	130	490	180	300	13	24
15	150	520	190	310	15	29
16	160	550	200	320	15	37

Thimbles

pennant line type

- **Material** : mild steel
- **Finish** : hot dipped galvanized
produced with a welded fillet plate
- **Certification** : a works certificate can be supplied upon request



G-6151

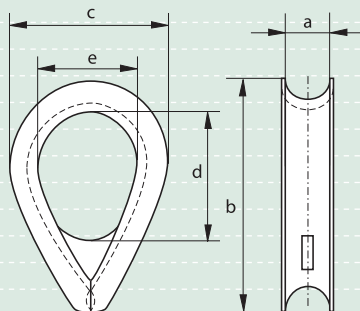

diameter wire rope	width groove	length	width	length inside	width inside	weight per piece
mm	a mm	b mm	c mm	d mm	e mm	kg
16	17	102	75	75	50	0.4
18	19	115	85	80	53	0.5
20	21	127	100	90	60	0.8
22	23	140	110	95	65	0.9
24	25	153	115	120	70	1
30	33	205	155	160	100	2.5
36	38	230	175	185	115	4
40	41	255	190	195	120	4.5
44	46	280	210	215	130	7
50	52	305	225	240	140	8.3
56	56	360	240	250	150	12.5
64	70	435	290	310	180	19.5
76	81	485	320	360	220	29
82	92	560	375	405	240	35
90	105	610	410	450	250	42
120	130	660	450	480	280	58



E-6180

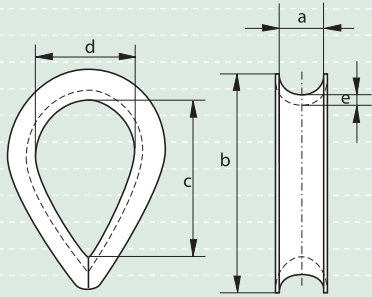

Thimbles for rope

- **Material** : mild steel
- **Finish** : electro-galvanized
- **Certification** : a works certificate can be supplied upon request

width groove	length	length inside	width inside	thickness back	weight per 100 pcs
a mm	b mm	c mm	d mm	e mm	kg
8	43	27	16	1	1.1
10	50	30	19	1.5	1.7
12	55	36	22	1.75	3
14	60	41	24	2	3.5
16	66	43	26	2.5	8
18	77	47	30	3	13
20	91	58	35	3	16
22	100	67	38	3	24
25	115	71	45	3	25
30	140	91	55	3	43
35	140	91	55	3	45
38	140	91	55	4	45

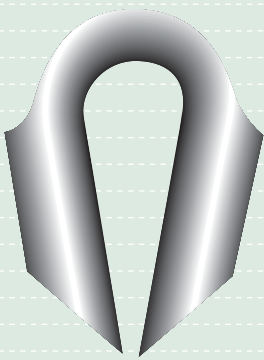

P-6190

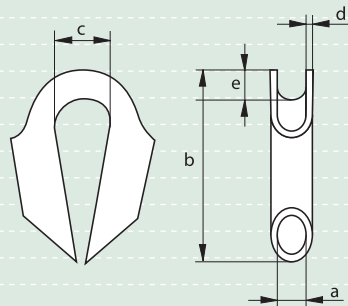

Thimbles tubular type

- **Material** : mild steel
- **Finish** : painted
- **Certification** : a works certificate can be supplied upon request

diameter wire rope	diameter	length	width inside	thickness	height	weight per piece
mm	a mm	b mm	c mm	d mm	e mm	kg
10	12	90	23	4	8	0.25
12	15	105	27	5	10	0.42
14	17	115	27	5	10	0.5
16	19	120	32	5	12	0.6
18	22	140	35	5	15	0.75
22	25	180	45	6	16	1.4
24	28	180	45	7	16	1.75
26	30	195	47	7	18	2
32	35	215	60	7	22	2.4
38	45	260	70	7	27	3.3
44	50	280	75	7	28	4.06

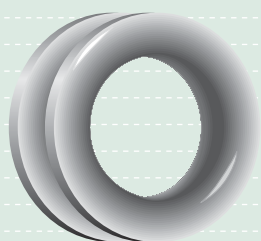

E-6143
G-6143

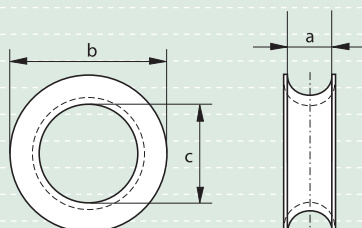

Round thimbles

ordinary type

- **Material** : mild steel
- **Finish** : up to and including 13 mm electro-galvanized
over 13 mm hot dipped galvanized
- **Certification** : a works certificate can be supplied upon request

width groove	width outside	width inside	weight per 100 pcs
a mm	b mm	c mm	kg
10	30	18	1.4
12	33	20	2.6
13	39	24	3.4
14	41	28	4
15	45	30	5
16	50	35	6.5
18	56	40	8
20	60	42	9
22	65	45	10.5
25	80	52	25
28	98	60	43
30	105	65	65
35	120	75	90
40	135	80	95

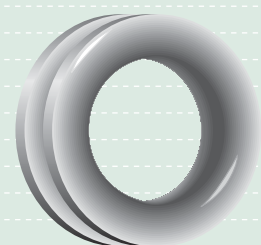

G-6144

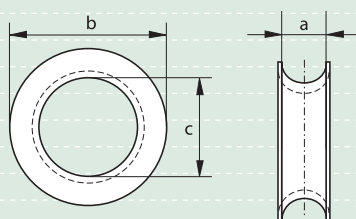

Round thimbles

container type

- **Material** : mild steel
- **Finish** : hot dipped galvanized
- **Certification** : a works certificate can be supplied upon request

width groove	width outside	width inside	weight per 100 pcs
a mm	b mm	c mm	kg
14	80	45	35
14	92	55	41
14	96	60	44
16	80	45	35
16	92	55	41
16	96	60	44
19	80	45	35
19	92	55	41
19	96	60	44

1
2
3
4
5
6
7
8
9
10
11
12
13
14
15
16